

Draft Governance Review

for the Leicester and Leicestershire
Combined Authority

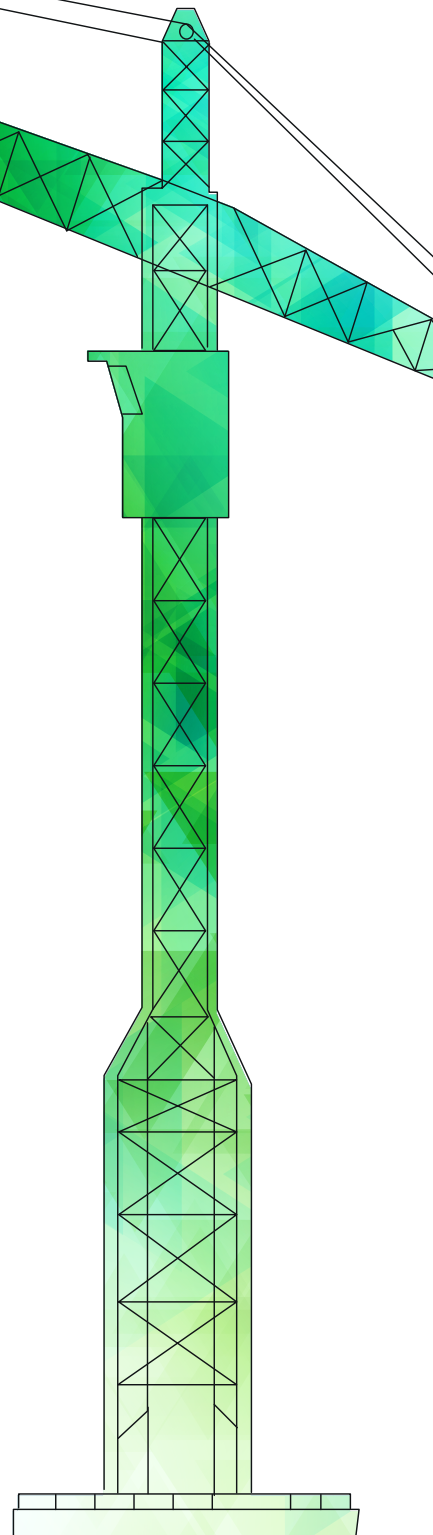

for consultation purposes



1. Introduction

On 25 June 2015 the Leaders of Leicester and Leicestershire's nine local authorities met as the Economic Growth Board for Leicester and Leicestershire and agreed proposals to review their governance arrangements in order to deliver their ambitious plans for growth in Leicester and Leicestershire.

This document details the findings of the governance review undertaken in accordance with Section 108 of the Local Democracy, Economic Development and Construction Act 2009, to review the effectiveness and efficiency of transport within the area and the arrangements to promote economic development and regeneration. The review aims to identify the most effective way in which policy and strategy on these major functions can be joined up across geographical boundaries. It has included consideration as to whether a Combined Authority or Economic Prosperity Board would be most likely to improve the overall economic conditions in Leicester and Leicestershire.

A period of consultation will be undertaken before a final decision is made by the nine local authorities regarding the governance model.

Contents

1. Introduction	2
2. Executive Summary	3
3. Methodology for the Governance Review	4
4. Review of Economic Evidence	4
5. Current Strategic Governance Arrangements	8
6. Limitations of the Current Arrangements	14
7. Case for Change	15
8. Options for Change	16
9. Summary of Preliminary Findings	21

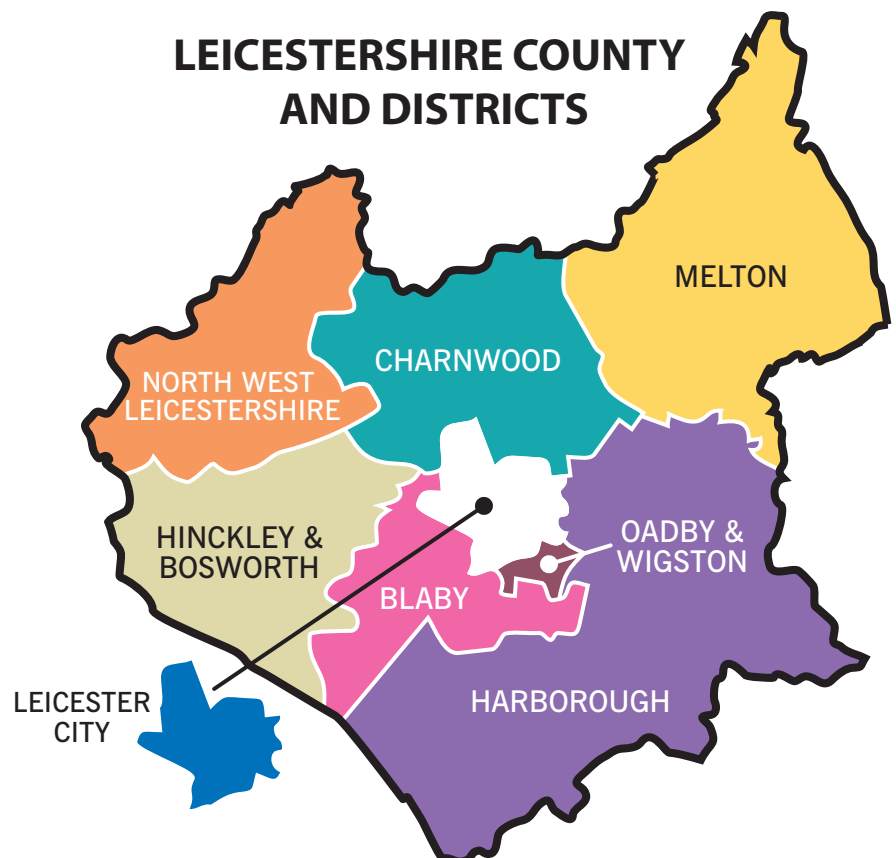

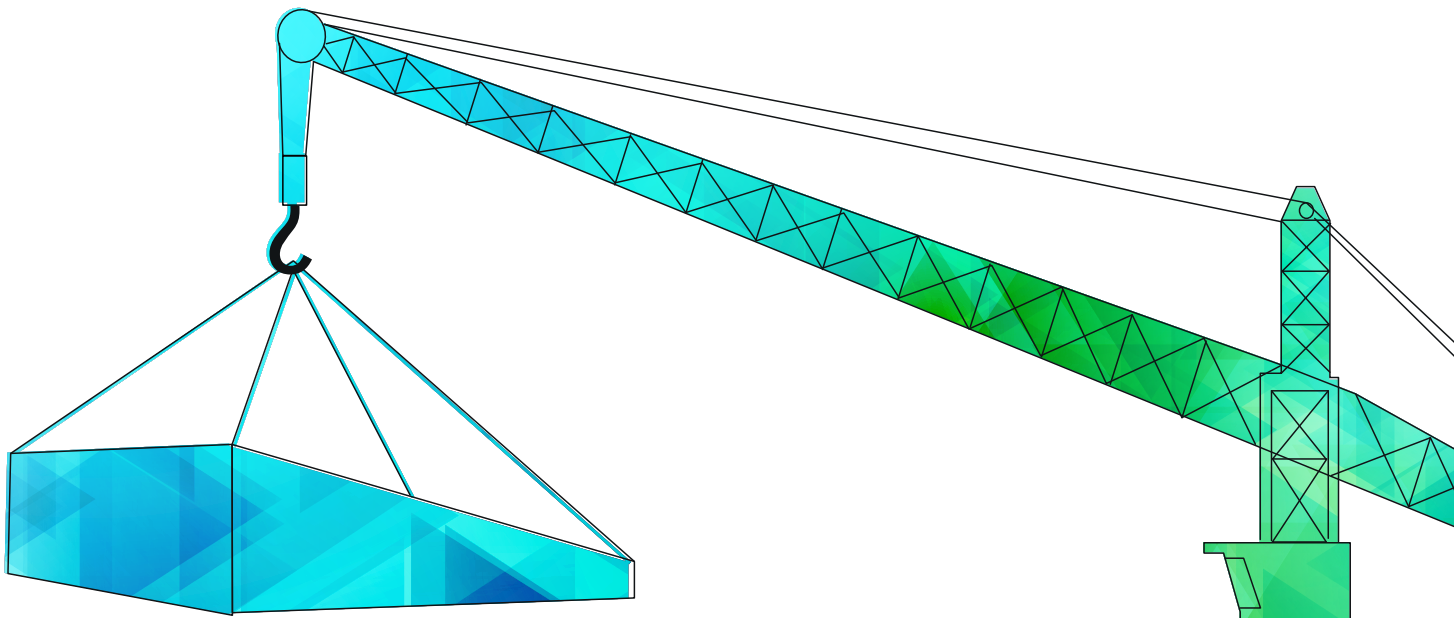

2. Executive Summary

The Governance Review has found that Leicester and Leicestershire functions as an integrated economic area. There are significant interdependencies between the City and the County. There are strong relationships with neighbouring areas. Partnership working on initiatives such as the Growth Deal and Enterprise Zones has further strengthened Leicester and Leicestershire as a functional economic area. Our partnership working has a strong track record that can be built on.

The case for change is compelling. There are a number of limitations within the current arrangements, largely relating to the lack of a single, formally constituted body responsible for taking decisions about economic growth and strategic transport, which has led to problems such as lack of clarity, duplication and inefficiency of decision making. The Review also concluded that the current arrangements inhibited long term strategic decision making and that they were not sufficient to support the ambitions of the area. A simpler, less cumbersome governance arrangement is needed to address the challenges that Leicester and Leicestershire will face in the future, as well as providing greater transparency and accountability.

The financial position facing local authorities should not be overlooked. Over the last four years, there have been significant reductions in the Government's funding of local authorities. Reductions in local government have been higher than in other parts of the public sector. It is therefore imperative that all future governance models are efficient and reduce duplication and waste wherever possible.

The Review finds that a Combined Authority is the best option for providing robust governance across Leicester and Leicestershire. It will act as a clear and effective platform for accelerating economic prosperity in Leicester and Leicestershire through the creation of integrated, strategic frameworks to enable the delivery of investment plans for planning, transport and skills.

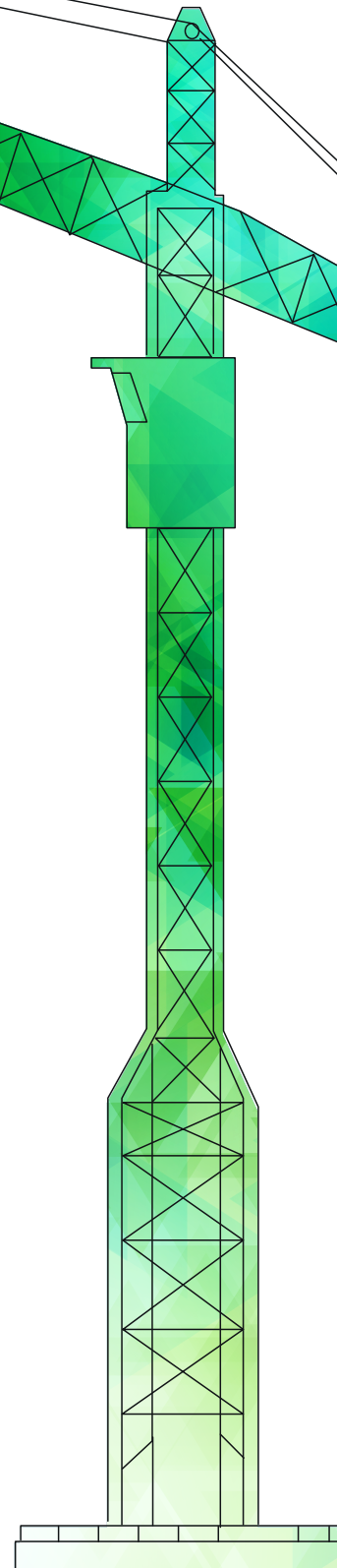

3. Methodology for the Governance Review

The governance review has comprised the following:-

- A review of the economic evidence in order to assess the effectiveness of current arrangements (August 2015);
- Desk research of possible future governance structures and an analysis of their advantages (August 2015);
- Stakeholder engagement on the draft review (September – October 2015);
- Final version submitted to the constituent councils for approval (November – December 2015).

4. Review of Economic Evidence

The full economic review is available as part of the Strategic Economic Plan and can be accessed via www.llep.org.uk/strategies-and-plans/our-strategic-economic-plan-sep/

(a) Summary of the Local Economy

Leicester and Leicestershire together make up the largest economy in the East Midlands. It is central to the prosperity of the Midlands as it is worth £19.4 billion per year, providing 435,000 jobs and hosting 33,000 trading businesses, many of which are in the manufacturing and logistics sectors.

Leicester and Leicestershire acts as a functional economic area with significant interdependencies between the City and County, sharing travel to work patterns, retail and leisure catchments and housing markets. Investment and growth within the area is predominately retained amongst the area's local population. Although it has strong relationships with neighbouring counties, the economic interdependencies and unique transport infrastructure and needs across Leicester and Leicestershire serve to make it a separate economic area.

The area benefits from a diverse industrial structure and is not dependent on the fortunes of any one sector or employer.

Although the service sector has grown in significance over the last 20 years, the economy was built upon a strong manufacturing base which remains a distinctive feature. The area also benefits from an excellent strategic location at the heart of the UK road and rail network and has the second largest freight handling airport in the UK.

The table below shows the top five employment sectors locally and the sectors that are more important locally than nationally. It demonstrates the importance of the manufacturing and logistics sectors in terms

of local employment and also shows a relatively high dependency on public sector related employment (health and education) which is especially marked in Leicester City (where one in four jobs are in the public sector).

Top 5 Employment Sectors (LLEP Figures – number of employees)	Sectors more important locally than nationally (percentage of LLEP workforce, percentage of England workforce)
Manufacturing (61,200)	Manufacturing (LLEP 14.1%, England 8.4%)
Health (51,700)	Logistics (LLEP 11.9%, England 8.8%)
Logistics (51,600)	Education (LLEP 9.6%, England 9.2%)
Education (41,700)	Motor Trades (LLEP 2.1%, England 1.8%)
Retail (41,600)	Mining, quarrying and utilities (LLEP 2%, England 1.1%)

It is also interesting to note those sectors where Leicester and Leicestershire have employment shares that are below the national levels. These include sectors which are associated with above average earnings and make a high contribution to GVA (Gross Value Added) including:

- Professional, scientific and technical sectors (especially in Leicester City);
- Finance and insurance;
- Information and communications;
- Property.

Analysis of sector structure has also revealed that there is a lower proportion of knowledge-intensive employment than is the case nationally (33% vs 38%). It is important to close this gap to provide a more resilient platform for growth and generate higher workplace earnings that will help to underpin service sector growth. The presence of three major universities each with their own area of distinct expertise provides Leicester and Leicestershire with an excellent opportunity to build a stronger knowledge economy. In addition the universities are hosts to a number of national centres.

The LLEP has recently published eight ‘sector growth plans’ (including a focus on; Textiles; Advanced Manufacturing and Engineering; Low Carbon; Food and Drink Manufacturing; Tourism and Hospitality) that will help shape and focus future funding and investment programmes to support economic growth and development in Leicester and Leicestershire.

Between December 2008 and December 2011, the number of people in employment fell by 25,000 in the LLEP area, or a fall of over 5%. This rate of decline was twice the national average over the same period.

Since March 2011, the labour market has bounced back with an annualised growth rate of 2.5%, this is generally around the long term growth trend. However, current Office for Budget Responsibility Employment Forecasts suggest a 0.7% growth in national levels of employment each year to 2017. The short term rebound in employment is not sustainable over the longer term without further intervention to accelerate the growth in jobs. In the LLEP area, a 0.7% annual increase in employment would not be enough to sustain current employment rates, with our working age population increasing by 1% per annum (2% in Leicester City).

The unemployment rate in Leicester City has been above the national average for many years and there are some pockets of higher than average unemployment in Leicestershire (especially in Coalville and Loughborough). Youth unemployment is also a significant concern in Leicester City. There are currently 16,605 JSA claimants in the LLEP area (30% of whom have been claiming benefits for over 12 months). A larger group of people are claiming the full range of out of work benefits (60,050 in August 2013 - 9.4% of the working age population).

The area faces substantial future demographic changes which will require the provision of substantial numbers of additional homes. Housing needs up to 2028 have been agreed by the nine local authorities in a memorandum of understanding, and work is underway to consider housing requirements beyond then as part of the preparation of a Strategic Growth Plan looking to 2050. A key aspect of this exercise will be to consider an appropriate spatial distribution of new housing which will support economic growth and which can be supported by appropriate infrastructure provision.

(b) Summary of Transport Evidence

There are two highway authorities delivering transportation services within the area: Leicestershire County Council and Leicester City Council. The nine local authorities in Leicester and Leicestershire are collaborating to produce strategic transport evidence looking to 2031. This will inform local planning and set the baseline for strategic planning to 2051.

The transport network is expected to see a 20% growth in traffic over the next 15 years.

This could present a substantial barrier to growth if not tackled through a range of major transport initiatives and smaller scale integrated transport interventions. Leicester City Council and Leicestershire County Council have worked closely together to deliver major corridor improvements and a very successful Local Sustainable Transport Fund (LSTF) programme. In the short to medium term, a further programme of corridor schemes and targeted smaller scale interventions, including proposed LSTF initiatives, will be required to help to manage the existing transport network effectively and prevent city development and growth across the urban area being frustrated. In addition, measures will be required to ensure Leicester can continue to have effective access to the Strategic Road and Rail Network, including the M1, M69, A5 and Midland Mainline and HS2.

With regard to the Strategic Rail Network, the two transport authorities, the LLEP and North West Leicestershire District Council are undertaking work to determine the future rail provision up to 2050. This links to the work on HS2 and Midlands Connect.

(c) Summary of Economic Successes through the LLEP

The Leicester and Leicestershire Enterprise Partnership (LLEP) has the full support and commitment of its public, private and voluntary sector partners and has built a strong spirit of partnership and sense of common purpose. It has a strong track record and is well placed to deliver at pace and provide value for money. Significant successes have already been achieved, including:-

- MIRA (located in Hinckley and Bosworth) has attracted the likes of Ashok Leyland and Bosch and created over 250 jobs;

- investing the Growing Places Fund to unlock the development of thousands of new homes and employment land and secure the location of Formula E (electric motorcar racing) to new international headquarters at Donington Park in North West Leicestershire;
- the City Mayor's Economic Action Plan which is investing over £60m in a range of regeneration, business support and skills programmes to transform Leicester's economy, and the County Council's Enabling Growth Plan which is investing £38m in activities to boost the county economy;
- securing £100m local growth funding to support development in infrastructure, including faster broadband, connectivity and skills, as well as £111m European Structural and Investment Funds to enable investment in 'place, people and business';
- through the City Deal, creating a flagship Business Growth Hub and running one of the most successful business grant programmes in the country; supporting the development of Loughborough University Science and Enterprise Parks and establishing the Leicester and Leicestershire to Work Programme;
- improving the Leicester North West (A50) transport corridor to facilitate mixed use urban extension in the regeneration area and mitigate the impacts of growth in the Coalville area and reduce congestion;
- the development of the Leicester and Leicestershire Integrated Transport Model (LLITM). Working in partnership with relevant authorities such as Highways England and the local planning authorities, LLITM has been successfully used to provide the evidence needed to underpin two adopted core strategies (Blaby and Harborough) and to underpin bids to secure over £25m to deliver schemes in Loughborough, Coalville, Leicester and Hinckley. Through the Strategic Planning Group LLITM is also being used to inform future strategic spatial planning beyond the current timeframe for core strategies (i.e. 2030 and beyond to 2050);
- the recent commencement of work on the Strategic Growth Plan to 2050, providing a longer term spatial strategy for Leicester and Leicestershire beyond the current planned growth (which extends to 2031). To lead this work, a Joint Strategic Planning Manager (funded by all Leicestershire Districts, the City Council, the County Council and the LLEP) has been appointed.

(d) Risks to the Economy

The following risks have been identified:-

- lack of suitable land for the most land intensive priority employment sectors (logistics and manufacturing);
- poor quality public realm and derelict sites requiring land assembly and infrastructure;
- inadequate transport infrastructure causing congestion and resulting in increased business costs;
- 70% SMEs have growth plans but need support;
- recruitment difficulties and skills shortages in key sectors and insufficient young people attracted to careers in sectors such as engineering, manufacturing and logistics.
- Lack of integration between growth and transport, which is necessary in order to shape the location of sites for employment and housing, particularly post 2031.

5. Current Strategic Governance Arrangements

The City of Leicester sits at the heart of the county and is governed by a unitary city council which has been managed under the directly elected mayor model of governance since 2011. The surrounding county is managed through a two-tier form of local government, with a county council and seven district councils. The Leicester and Leicestershire Enterprise Partnership (LLEP) operates co-terminously with the city and county boundary.

All nine councils in Leicester and Leicestershire have a strong commitment to joint working with business and other partner organisations to deliver economic growth. There are numerous examples of effective partnership working, particularly through the LLEP which has a strong track record of delivery.

(a) Existing Arrangements to Promote Economic Development and Regeneration

The diagram below summaries the current governance arrangements for the delivery of economic development and growth, as set out in the LLEP’s Strategic Economic Plan.

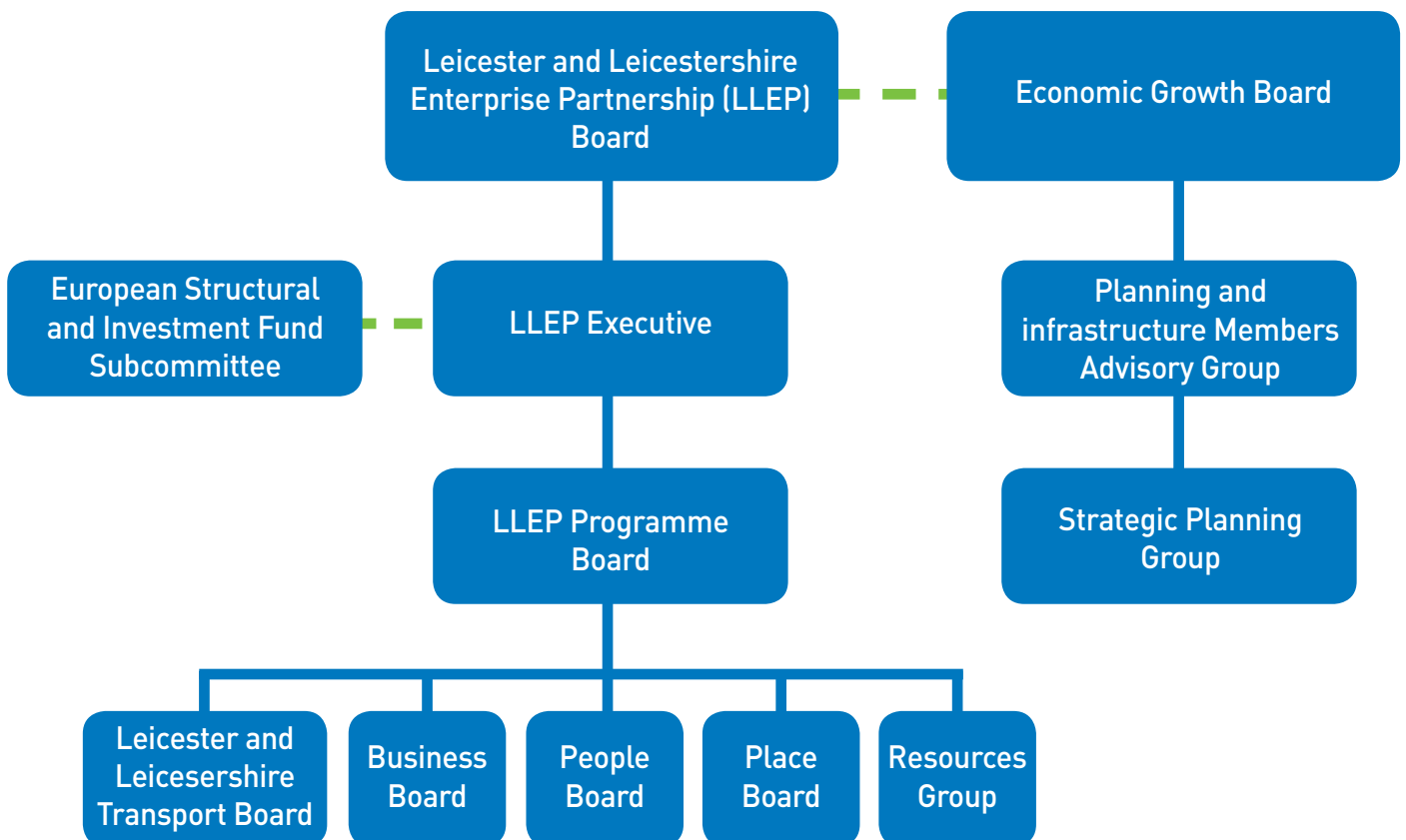

Strategic governance of the programme for economic development and growth is provided through the Economic Growth Board and the LLEP Board. To ensure alignment between these two Boards, there is a degree of shared membership, with the Chairman of the LLEP sitting on the Economic Growth Board in an observer capacity and four local authority Leaders who are members of the Economic Growth Board sitting on the LLEP Board.

The remit of each of the above bodies involved in economic development and regeneration is set out below, along with some other bodies that are not part of this structure but contribute to this area of work:-

(i) Economic Growth Board for Leicester and Leicestershire

The Economic Growth Board provides strategic oversight of economic development delivery by the local authorities. It informs objectives and prioritisation for investment programmes and the management of pooled local authority resources to support the projects outlined in the LLEP's Strategic Economic Plan.

The Economic Growth Board is comprised of the City Mayor, the County Council Leader and the seven District Council Leaders. The Chairman of the LLEP also attends the Board in an observer capacity.

(ii) Planning and Infrastructure Members Advisory Group

The purpose of the Members Advisory Group is to oversee strategic land-use planning work in Leicester and Leicestershire and support fulfilment of the Duty to Co-operate, as required by the Localism Act 2011 and the National Planning Policy Framework March 2012, which states that Local Planning Authorities, when preparing a development plan document such as a Local Plan must demonstrate effective and collaborative working.

The Member Advisory Group delivers its role through:-

- facilitating the sustainable growth of Leicester and Leicestershire by assisting in the discharge of the statutory Duty to Cooperate (section 110 of the Localism Act 2011) and advising on the preparation of the Strategic Growth Plan;
- providing Member-level advice to the Strategic Planning Group (the officer-level group tasked with preparing a non-statutory Strategic Growth Plan for consideration by Members) on all matters relating to the preparation of the Plan including its nature, form, content and programme;
- conveying the views held by constituent authorities on matters relevant to a non-statutory Strategic Growth Plan and having regard to the aspirations of the wider stakeholder group in the preparation of the Plan including matters relating to the Combined Authority proposal and the refresh of the Strategic Economic Plan prepared by the LLEP;
- ensuring that the preparation of a non-statutory Strategic Growth Plan fully integrates with existing or emerging spatial provisions of all up-to-date, National Planning Policy Framework (NPPF) compliant local plans across the Leicester and Leicestershire area in every strategic and spatial interest of acknowledged importance.

The membership comprises the City Mayor, Planning Portfolio Holders and District Leaders, the County Council's Lead Member for Highways also attends. This is currently an informal group without any decision making powers.

(iii) Strategic Planning Group

The Strategic Planning Group is an officer group which steers and manages strategic planning collaboration and co-operation across Leicester and Leicestershire. It is chaired by a District Council Chief Executive and comprises senior council officers and officers from the Homes and Communities Agency. It is supported by the newly appointed Joint Strategic Planning Manager.

(iv) Leicester and Leicestershire Enterprise Partnership (LLEP) Board

The Leicester and Leicestershire Enterprise Partnership (LLEP) was formed in May 2011. It is a strategic body led by a Board made up of 15 local government and business leaders as well as senior education and third (voluntary) sector representatives. It is chaired by a leading business representative. The local government representatives are elected members.

The LLEP's vision is to "Create a vibrant, attractive and distinctive place with highly skilled people making Leicester and Leicestershire the destination of choice for successful businesses."

Its aim, by 2020, is to have:

- Created 45,000 new jobs;
- Leveraged £2.5bn of private investment;
- Increased GVA (Gross Value Added) by £4bn from £19bn to £23bn.

It will do this by driving forward regeneration and growth of the local economy, by:

- Working with Government to set out key investment priorities for Leicester and Leicestershire;
- Engaging with business, local authorities, Higher Education, Further Education, the voluntary sector and other stakeholders;
- Facilitating local partnership working and relations with national Government
- Influencing national Government economic policy and spending;
- Investing LLEP funding and aligning partner resources;
- Through its investments, influence and activities ensure positive outcomes for the local economy.

(v) LLEP Executive

The LLEP Executive Group is an officer group which ensures implementation of the Board's strategic priorities, programmes and projects, including oversight of the development of the City Deal, European Structural and Investment Fund (ESIF) Strategy and the LLEP's Strategic Economic Plan. It also provides advice to the Board and surety that resources are being managed effectively.

Membership of the LLEP Executive comprises the LLEP Director (Chairman of the Executive), senior local authority officers, senior Higher Education, Further Education, third sector representation and a business representative nominated by the Business Council, an umbrella organisation for business organisations, with appropriate officer input from national Government.

(vi) LLEP Programme Board

The Programme Board has only recently been established through the Local Assurance Framework. It reports to the LLEP Board and has the following purpose:-

- To maintain the integrity of the LLEP Programme, as defined by the Strategic Operational Plan of the LLEP, which considers projects in relation to the Strategic Economic Plan;
- To agree with the Resources Group on particular routes to funding for the programme, in line with the LLEP finance strategy;
- To make recommendations to the LLEP Board on projects and programmes to approve for funding;
- To oversee the quality of business cases required for project approvals;
- To ensure the integrity of the wider Local Assurance Framework process.

Membership comprises both private sector and public sector member and officer representatives with a private sector chair.

(vii) People Board

The People Board supersedes the former Employment and Skills Board and is responsible for:

- Overseeing the development and review of the People Chapter of the Strategic Economic Plan (SEP) and leading the strategy and direction for skills development and employment support;
- Overseeing and co-ordinating the delivery of key projects and programmes
- Providing delivery assurance to the LLEP Executive of the delivery of projects and programmes;
- Making recommendations to and advising the LLEP Executive and Board about future investment opportunities;
- Directing and managing individual project boards and teams;
- Managing risks and issues, escalating to the LLEP Executive where appropriate;
- Engaging stakeholders in the development and review of the SEP and delivery of programmes.

Membership comprises senior local authority officers and representatives of Higher Education, Further Education, the third sector, business and the Department for Work and Pensions

(Viii) Business Board

The Business Board is accountable to the LLEP Executive and is responsible for

- Overseeing the development and review of the Business Chapter of the SEP and leading the strategy and direction for business support and innovation;
- Overseeing and co-ordinating the delivery of key projects and programmes including the Growth Deal and ESIF programmes;
- Providing delivery assurance to the LLEP Executive of the delivery of projects and programmes;
- Making recommendations to and advising the LLEP Executive and Board about future investment opportunities;
- Directing and managing individual project boards and teams;
- Managing risks and issues, escalating to the Executive where appropriate;
- Engaging stakeholders in the development and review of the SEP and delivery of programmes.

Membership comprises senior local authority officers, senior Higher Education, Further Education, and third sector representation and business representatives.

(ix) Place Board

The Place Board is accountable to the LLEP Executive and is responsible for:

- (i) Overseeing the development and review of the Place Chapter of the Strategic Economic Plan (SEP) and leading the strategy and direction for physical infrastructure to support growth:

LLEP Strategic Economic Plan 2014 – 2020

Growth Areas

- Leicester Urban Area;
- East Midlands Enterprise Gateway;
- Coalville Growth Corridor;
- Loughborough;
- South West Leicestershire.

Transformational Priorities

- Leicester Launchpad;
- East Midlands Gateway Strategic Rail Freight Interchange;
- Loughborough University Science and Enterprise Parks;
- MIRA Technology Park Enterprise Zone.

Growth Programmes

- Market Towns and Rural Leicestershire;
- Infrastructure, Workspace and Cultural Development.

- (ii) Overseeing and co-ordinating the delivery of key projects and programmes including the Growth Deal and EU Structural Investment Funds (ESIF) programmes;
- (iii) Providing delivery assurance to the Executive of the delivery of projects and programmes;
- (iv) Making recommendations to and advising the LLEP Executive and Board about future investment opportunities;
- (v) Directing and managing individual project boards and teams;
- (vi) Managing risks and issues, escalating to the Executive where appropriate; and
- (vii) Engaging stakeholders in the development and review of the SEP and delivery of programmes.

Membership comprises officers from the nine local authorities in Leicester and Leicestershire, the Homes and Communities Agency and the LLEP.

(x) Resources Group

The Resources group is accountable for the funding the LLEP receives from Central Government. It also manages the LLEP's own budget and distributes funds as appropriate.

Membership comprises officers from the LLEP and from the nine local authorities in Leicester and Leicestershire.

(xi) European Structural and Investment Funds (ESIF) Sub-committee

The ESIF Committee governs the LLEP's ESIF programme. The Committee comprises business partners and representatives from the voluntary and public sectors. Public sector representatives include both elected members and officers.

(b) Arrangements to Ensure the Effectiveness and Efficiency of Transport within the Area

(i) Leicester and Leicestershire Transport Board (LLTB)

The LLTB was established in response to the national Government's intention to devolve funding for local major transport schemes to Local Transport Bodies from 2015. Its primary role is to decide which transport investments should be prioritised, to review and approve individual business cases for those investments, and to ensure effective delivery of the programme. Its role is to ensure value for money and sound decision making.

The LLTB pre-dates the LLEP but has been integrated into the LLEP substructure and is currently overseen by the LLEP Programme Board. It is a voluntary partnership between the Leicester and Leicestershire Enterprise Partnership and elected members from Leicester City Council and Leicestershire County Council. A Leicestershire District Council member has also been invited to join the Board, but in a non-voting advisory capacity.

6. Limitations of the Current Arrangements

The current partnership arrangements described above have delivered a significant number of development and growth projects - 5000 new jobs and support to the growth of 3000 new businesses across the city and county - within the last three years. An effective framework has been developed to manage and commission the £100m Local Growth Fund which will unlock a further £160m of investment and create at least a further 2500 jobs and 1300 homes.

However, the current partnership arrangements have a number of constraints, namely:-

- There is no single formally constituted body with responsibility for taking decisions related to economic growth and strategic transport across the sub-region. This has led to a lack of clarity about decision making processes and responsibilities.
- The current bodies that are in place are voluntary and rely on good relations between partners and a mutual interest in working collaboratively.
- As none of the current bodies are formally constituted, it has not been possible for any of the constituent authorities to delegate powers to them. This means that any decisions related to economic growth and transport need to be taken by all the relevant local authorities. This results in longer decision making timescales, duplication of effort and a lack of transparency leading to a potential for confusion.
- The current governance arrangements are not sufficient for the ambitions of the area in terms of long term funding commitments for transport investment, devolution of funding and the ability to commission skills programmes locally and enhanced funding and finance powers through the establishment of new enterprise zones to help deliver priority growth areas.
- As there is no single entity with responsibility for taking decisions on economic development and

transport at a sub-regional level, there is no straightforward mechanism for coherent long term strategic planning decisions to be made collectively by all local authorities about the future direction of growth, including distribution of employment and housing land in the city and county and key infrastructure investment. Similarly, there is no cohesive long term approach to strategic transport planning which is a distinct function. It also inhibits shared understanding about the sub-region as a single economic area and a risk that each council acting alone will have limited control or influence over the key drivers of economic growth. This is particularly important in the case of developing relationships with neighbouring LEPs and Housing Market Areas.

- There is no vehicle to provide a single, coherent response to major, national infrastructure investments such as strategic road and rail projects.
- There is no arrangement for binding decisions on strategic land use planning to be taken collectively. This will not give investors, central government and other agencies assurance and confidence in the deliverability of the sub-region's plans for economic growth. There is also no single mechanism for discussing strategic planning and infrastructure with adjacent local authority areas.
- The skills agenda is not at the forefront of current arrangements and existing governance structures have not prioritised it. There is no single, strategic commissioning body to drive and deliver locally-led solutions to improve the delivery of skills training and development.

7. Case for Change

The nine local authorities of Leicester and Leicestershire firmly believe that they can build upon their successes by strengthening and formalising partnership arrangements. In particular, this would allow them to work more closely together with Government and the LLEP to enhance their collective impact on economic growth.

Strengthened partnership arrangements would also create a clear and effective platform for accelerating economic prosperity in Leicester and Leicestershire through the creation of integrated strategic frameworks to enable the delivery of investment plans for planning, transport and skills.

In the current financial climate, where there have been significant reductions in the Government's funding of local government over the last four years which are set to continue in the medium term, it is imperative to have governance arrangements in place that are efficient and reduce both duplication and the timescales for delivery of investment in economic growth.

A Combined Authority will represent clear and co-ordinated governance for Leicester and Leicestershire and will form the foundation for an ambitious devolution deal for the area.

8. Options for Change

This review considers the following options:-

1. Maintaining the status quo;
2. Establishing a Joint Committee;
3. Establishing an Economic Prosperity Board;
4. Establishing a Combined Authority.

These options are considered in the light of the requirement that the Governance Review determines whether the existing governance arrangements for economic development, regeneration and transport in the area are effective or whether the area would benefit from changes, including establishing a new Economic Prosperity Board or Combined Authority.

Option 1: Maintaining the Status Quo

Maintaining the status quo means that the governance arrangements will not be sufficient for the ambitions of the area. These ambitions are:-

- Long term funding commitments for transport investment;
- Devolution of funding and the ability to commission skills programmes locally;
- Enhanced funding and finance powers through the establishment of new enterprise zones to help deliver priority growth areas.

Under the current arrangements, there is no single body which could hold devolved funding and undertake commissioning on a sub-regional basis.

In addition, the lack of a single decision-making body with responsibility across the spectrum of economic development, regeneration and transport means that there is no binding forum where a long term view on policy and strategy can be taken. Without this, it would not be considered prudent for third parties to make long term funding commitments.

Maintaining the status quo would also mean that the area would miss out on the benefits of more efficient partnership working and would leave Leicester and Leicestershire behind a number of other parts of the country which have already, or are in the process of, strengthening and aligning their decision making process in relation to transport and economic development and regeneration. In addition, it would mean that Leicester and Leicestershire would be unable to pursue a devolution deal.

The current arrangements would not allow the sub-region to benefit from a single democratic and financially accountable model which is a legal entity in its own right and can provide the necessary certainty, stability and democratic accountability to allow for long-term, strategic economic decisions to be made.

In conclusion, maintaining the status quo would mean difficulties in accessing new funding and powers in line with the ambitions of the area, leaving Leicester and Leicestershire behind other areas economically with all the attendant implications for local residents. It would also perpetuate the inefficiencies in the current system.

Option 2: Establishing a Joint Committee

Background

Section 102 of the Local Government Act 1972 enables two or more local authorities to set up a Joint Committee to discharge their functions jointly. These arrangements must comply with the Local Authorities (Arrangements for the Discharge of Functions) (England) Regulations 2012. Joint Committees may be decision-making or advisory. The councils concerned determine the numbers of councillors, terms of office and geographic areas of operation of joint committees. It would be possible to co-opt a non-local authority member to a Joint Committee; however they would not be able to vote.

Most Joint Committees appoint a 'lead/accountable' council; some do this on a rotating basis. They have no legal status, cannot impose financial obligations on their constituent authorities, and have no powers to levy council tax. They do not require the involvement of national Government or Parliament and so can be set up within a matter of months.

The Joint Committee model allows an area to demonstrate effective decision making and political oversight for the management of funding that is allocated to the LEP.

The County Council currently manages two joint Committees operating in the area, the Eastern Shires Purchasing Organisation (ESPO) and East Midlands Shared Services (EMSS) and has considered the operation of these in the analysis below.

Analysis

The functioning of a Joint Committee depends upon goodwill and the desire for collaboration which characterises the current arrangements and therefore will not address the deficiencies associated with the status quo. Each authority would need to authorise and delegate functions to the Joint Committee. Councils are also able to withdraw the delegation at any point in the future which poses a significant risk in terms of a lack of stability and certainty which is required to enable long term, strategic economic decisions to be made.

Joint Committees cannot be accountable bodies for funding purposes, nor can they employ staff due to their lack of legal status. Ultimate responsibility for finances remains with the host council. This will not meet the ambitions of Leicester and Leicestershire, which include both the devolution of funding and enhanced funding and finance powers.

Securing new investment and responding to a rapidly changing landscape requires local authority partners in Leicester and Leicestershire to be able to act with agility and pace. If circumstances require further functions to be delegated to a Joint Committee than were originally agreed then it would not be possible for it to act in such a way because of the need for this to be agreed through the formal decision making processes at each of the constituent councils.

In conclusion, the establishment of a Joint Committee would not meet the ambitions for Leicester and Leicestershire. The model represents a significant risk to partnership working which will impact on the ability to secure long term funding commitments. In addition, the lack of legal status and financial accountability means that the same difficulties in accessing new funding and powers presented by status quo will be encountered.

Option 3: Establishing an Economic Prosperity Board.

Background

Economic Prosperity Boards were introduced under the Local Democracy, Economic Development and Construction Act 2009 to enable the integration of economic development (but not transport functions). As a statutory body, an Economic Prosperity Board would have legal personality and is thus considered by central government to provide a strong basis for taking on devolved powers and funding relating to economic development and regeneration, for example accountable body status for an economic development single pot or European Union funding.

Economic Prosperity Boards cannot impose levies on constituent authorities and do not have borrowing powers. The establishment of an Economic Prosperity Board is subject to the same process as for Combined Authorities.

Analysis

An Economic Prosperity Board could strengthen current partnership arrangements by providing a formal structure to lead collaboration between the Leicester and Leicestershire local authorities on sub-regional economic development and regeneration. It could also provide a stable mechanism for strategic decision making on economic issues across the sub-region. This would be of some benefit because it would enable long term funding commitments to be made.

Economic Prosperity Boards can take a strategic view of economic development and where investment should be made to support long-term, sustainable economic growth across the area. They also enable trade-offs to be made at a strategic level, taking into account what is best for the area as a whole.

An Economic Prosperity Board would be a single body that could represent the economic needs and strengths of Leicester and Leicestershire to partners and investors. It would also enable partnerships of authorities to demonstrate that they are committed to long-term joint working. It would facilitate transparency, accountability and visible leadership for sub-regional areas.

However, the major disadvantage of an Economic Prosperity Board is that it does not include transport functions. Transport is essential to the ambitions for growth in Leicester and Leicestershire. The interdependencies between economic growth and transport are so significant that it would be irrational to establish a governance arrangement that addressed one area but not the other as it would prevent a fully integrated approach to the two areas. The need for separate governance arrangements to address transport issues would be cumbersome and would create a wasteful duplication of effort.

It also worth noting that no Economic Prosperity Boards have been created to date, which means that there is no opportunity to learn for experience in other areas.

Option 4: Establishing a Combined Authority

Background

Combined Authorities were introduced under the Local Democracy, Economic Development and Construction Act 2009 to enable councils to integrate economic development and transport functions and decision-making across a functional economic area. A Combined Authority operates as a public body with its own legal personality, can impose a levy on constituent authorities and can borrow money for transport purposes.

It is important to note that Combined Authorities are not a merger of existing Local Authorities; they can only take on certain functions with a very specific remit. In addition, the legislation allows for flexibility in establishing Combined Authorities.

Analysis

The advantages of an Economic Prosperity Board previously outlined all apply to a Combined Authority as both options are formally constituted legal entities and would provide a stable mechanism for long term strategic decision making and a single body that can represent the needs of Leicester and Leicestershire to investors and partners.

Both options enable a streamlining of arrangements, reduce duplication, would be able to take on developed powers from national Government and can have additional powers delegated to them from constituent councils if they choose to do so.

The significant difference between a Combined Authority and an Economic Prosperity Board, which makes the Combined Authority option much more attractive for Leicester and Leicestershire, is that a Combined Authority would have powers relating to both economic development and strategic transport. The Combined Authority model would provide a simple means of fully aligning and coordinating transport planning and wider economic development and regeneration, including strategic planning, across a sub-region. This would mean that economic development and regeneration and transport initiatives could be aligned, co-ordinated and delivered swiftly and efficiently by a single body.

The creation of a Combined Authority will allow Leicester and Leicestershire to realise its ambitions by bringing together, in a single legally recognised body, the key decision making powers for strategic transport and economic development and planning. It is impossible to separate these two functions, given their high level of interdependency and being able to present a coherent, long term vision across the two areas would facilitate long term planning designed to improve the economic conditions and performance of the area including an improvement in the effectiveness and efficiency of transport. This vision will be based on a single evidence base for the whole area, ensuring data and analysis relating to economic, planning and transportation matters are consistently defined, collected and applied.

A Combined Authority will enable a unified approach to insight, evidence and intelligence which will ensure that the understanding of the complex interdependencies between individuals businesses, jobs, skills, housing, health and financial dependence is of a higher quality thereby ensuring better use of resources on a local level.

A Combined Authority will enable a shared understanding about Leicester and Leicestershire as a single economic area across the nine local authorities and would create a strategic framework for economic development and transport which would ensure consistency in local decision making. It would also increase the control and influence of the constituent councils across the key drivers of economic growth.

A further advantage to the Combined Authority model is that it would provide a framework for a single, coherent response from Leicester and Leicestershire to be made to national initiatives relating to planning or infrastructure. As a single entity, it would also enhance Leicester and Leicestershire's ability to liaise with neighbouring areas on issues of mutual interest, particularly as a number of neighbouring areas are in the process of becoming Combined Authorities.

Indeed, a number of areas in the country have already established Combined Authorities, or are in the process of doing so. If Leicester and Leicestershire choose not to establish a Combined Authority they risk getting left behind other areas and missing out on crucial government funding, such as devolution deals, due to not having sufficiently robust governance arrangements in place.

9. Summary of Preliminary Findings

The following table sets out an assessment of the options that have been considered by this review:-

Option	Evaluation	Rationale
Maintain the Status Quo	No	Maintaining the status quo would mean difficulties in accessing new funding and powers in line with the ambitions of the area. It would leave Leicester and Leicestershire behind other areas and would therefore be likely to have a detrimental impact on the economy of the area in the future. It would not strengthen the governance processes which largely rely on informal arrangements.
Joint Committee	No	The establishment of a Joint Committee would strengthen the current partnership arrangements and place them on a more formal basis. However, there is a lack of stability and certainty which is unlikely to secure long term funding commitments. In addition, the lack of legal status and financial accountability means that the same difficulties in accessing new funding and powers presented by status quo are likely to be encountered.
Economic Prosperity Board	No	An Economic Prosperity Board would provide strategic direction and accountability for economic development and regeneration and would ensure that a single formal decision-making body was in place for this. However, strategic transport would not be included in these arrangements, thus greatly limiting the scope for increased effectiveness and efficiency.
Combined Authority	Yes	A Combined Authority with devolved funding would create a clear and effective platform for accelerating economic prosperity in Leicester and Leicestershire through the creation of integrated, strategic frameworks to enable the delivery of investment plans for planning, transport and skills.

You can view the latest information in a number of ways

Visit us online www.llca.org.uk - this web page will be kept up-to-date with the latest information and developments. You'll also be able to access the survey here.

Alternatively, you can telephone **0116 305 7243** to ask for information in printed or alternative formats.

ਜੇ ਆਪ ਆ ਮਾਹਿਤੀ ਆਪਨੀ ਆਖਾਮਾਂ ਸਮਝਵਾਮਾਂ ਥੋੜੀ ਮਦਦ ਈਝਤਾਂ ਭੀ ਤੋ 0116 305 7243 ਨੰਬਰ ਪਰ ਫ਼ੋਨ ਕਰਥੋ ਅਨੇ ਅਮੇ ਆਪਨੇ ਮਦਦ ਕਰਵਾ ਆਵਥਾ ਕਰੀਥੁੰ।

ਜੇਕਰ ਤੁਹਾਨੂੰ ਇਸ ਜਾਣਕਾਰੀ ਨੂੰ ਸਮਝਣ ਵਿਚ ਕੁਝ ਮਦਦ ਚਾਹੀਦੀ ਹੈ ਤਾਂ ਕਿਰਪਾ ਕਰਕੇ 0116 305 7243 ਨੰਬਰ ਤੇ ਫ਼ੋਨ ਕਰੋ ਅਤੇ ਅਸੀਂ ਤੁਹਾਡੀ ਮਦਦ ਲਈ ਕਿਸੇ ਦਾ ਪ੍ਰਬੰਧ ਕਰ ਦਵਾਂਗੇ।

এই তথ্য নিজের ভাষায় বুঝার জন্য আপনার যদি কোন সাহায্যের প্রয়োজন হয়, তবে 0116 305 7243 এই নম্বরে ফোন করলে আমরা উপযুক্ত ব্যক্তির ব্যবস্থা করবো।

اگر آپ کو یہ معلومات سمجھنے میں کچھ مدد درکار ہے تو براہ مہربانی اس نمبر پر کال کریں 0116 305 7243 اور ہم آپ کی مدد کے لئے کسی کا انتظام کر دیں گے۔

假如閣下需要幫助，用你的語言去明白這些資訊，請致電 0116 305 7243，我們會安排有關人員為你提供幫助。

Jeżeli potrzebujesz pomocy w zrozumieniu tej informacji w Twoim języku, zadzwoń pod numer 0116 305 7243, a my Ci pomożemy.

This information is also available in Easy Read format



Call **0116 305 7243**
or email
questions@llca.org.uk

